

# Moonlight Run 5K

Williamsville, NY

Measured By: Jeff John

Date of Measurement: April 24, 2011

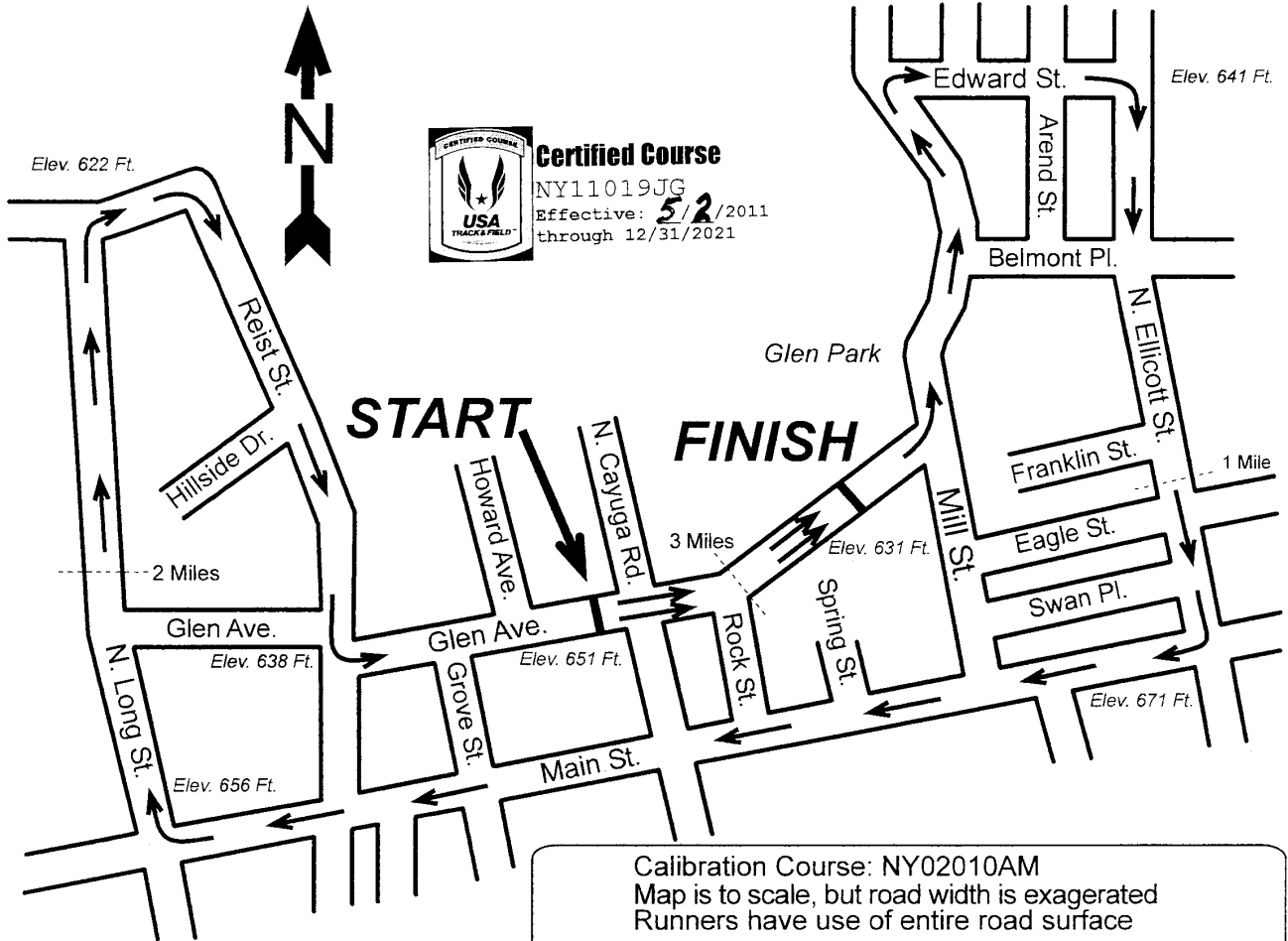

Calibration Course: NY02010AM  
 Map is to scale, but road width is exaggerated  
 Runners have use of entire road surface

**START:** On Glen Ave at Pole NG 184  
**1 Mile:** On N. Ellicott St., 21' before Pole NG 49  
**2 Mile:** On N. Long St., 7' past Pole NG 100  
**3 Mile:** On Glen Ave., 30' past Pole NG 218  
**FINISH:** On Glen Ave., 24' past Pole NG 273

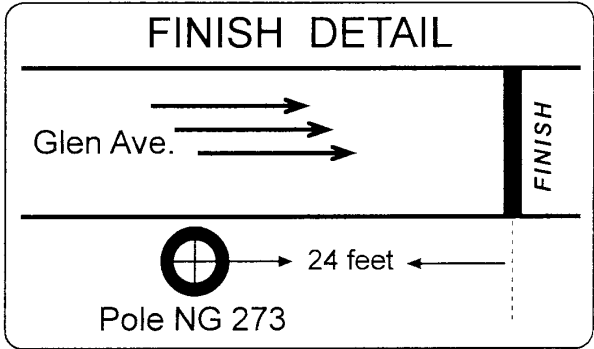
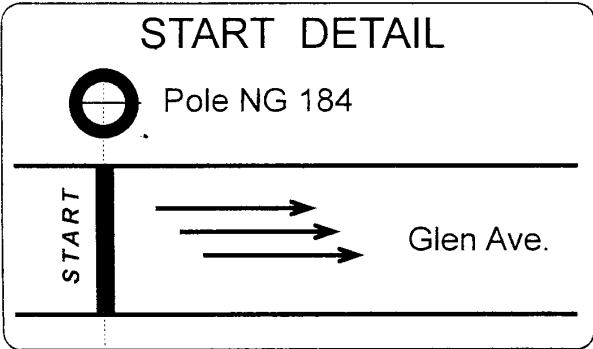



*Road Running Technical Council*  
*USA Track & Field*  
**Measurement Certificate**

recognized by



Name of the course Moonlight Run 5K Distance 5 km  
 Location (state) NY (city) Williamsville  
 Type of course: road race  calibration  track  Configuration: loop (1x)  
 Type of surface: paved 100 % dirt - % gravel - % grass - % track - %  
 Elevation (feet above sea level) Start 652 Finish 631 Highest 671 Lowest 631  
 Straight line distance between start & finish 263 m Drop 1.28 m/km Separation 5.26 %  
 Measured by (name, address, phone & e-mail) Jeff John, P.O. Box 608, Amherst, NY 14226;  
716-677-6104; jeff@buffalorunners.com  
 Race contact (name, address & phone) Deborah Timineri, 4152 Vineyard Dr., 14221  
716-634-1760

Measuring Methods: bicycle  steel tape  electronic distance meter   
 Number of measurements of entire course: 2 Date(s) when course measured: April 24, 2011  
 Race date: May 21, 2011 Course certification effective date: May 2, 2011  
 Replaces: n/a (if applicable) Certification code: NY11019JG

Notice to Race Director  
Use this Certification Code in *all* public  
announcements relating to your race.

***Be It Officially Noted That***

Based on examination of data provided by the above named measurer, the course described above and in the map attached is hereby certified as reasonably accurate in measurement according to the standards adopted by the Road Running Technical Council. If *any* changes are made to the course, this certification becomes void, and the course must then be recertified.

*Validation of Course* — In the event a National Open Record is set on this course, or at the discretion of USA Track & Field, a validation remeasurement may be required to be performed by a member of the Road Running Technical Council. If such a remeasurement shows the course to be short, then all pending records will be rejected and the course certification will be cancelled.

*This certification expires on December 31 in the year* 2021

**AS NATIONALLY CERTIFIED BY:**

Digitally signed by James Gilmer  
DN: cn=James Gilmer, o=ou, email=jim.gilmer@gmail.com, c=US  
Date: 2011.05.04 20:15:46 -04'00'

Date: May 4, 2011

James A. Gilmer, USATF/RRTC Regional Certifier, New York  
232 Van Wies Point Rd., Glenmont, NY 12077-4222 • 518-427-9374 • jim.gilmer@gmail.com

20110504